

.90M/1.0M/1.2M Offset Antenna  
Receive only and Transmit-Receive

# PATRIOT

## LIMITED TWELVE (12) MONTH WARRANTY

This PATRIOT ANTENNA equipment is warranted to be free from defects in material and workmanship under normal use and service. PATRIOT ANTENNA shall repair or replace defective equipment, at no charge, or at its option, refund the purchase price, if the equipment is returned to PATRIOT ANTENNA not more than twelve (12) months after shipment. Removal or reinstallation of equipment and its transportation shall not be at cost of PATRIOT ANTENNA except PATRIOT ANTENNA shall return repaired or replaced equipment freight prepaid.

This Warranty shall not apply to equipment which has been repaired or altered in any way so as to affect its stability or durability, or which has been subject to misuse, negligence or accident. This Warranty does not cover equipment which has been impaired by severe weather conditions such as excessive wind, ice, storms, lightning, or other natural occurrences over which PATRIOT ANTENNA has no control, and this Warranty shall not apply to equipment which has been operated or installed other than in accordance with the instructions furnished by PATRIOT ANTENNA.

Claimants under this Warranty shall present their claims along with the defective equipment to PATRIOT ANTENNA immediately upon failure. Noncompliance with any part of this claim procedure may invalidate this warranty in whole or in part.

THIS WARRANTY IS EXPRESSLY IN LIEU OF ALL OTHER AGREEMENTS AND WARRANTIES, ANY IMPLIED WARRANTY OF MERCHANTABILITY OR FITNESS FOR A PARTICULAR PURPOSE IS LIMITED IN DURATION TO THE DURATION OF THIS WARRANTY. PATRIOT ANTENNA DOES NOT AUTHORIZE ANY PERSON TO ASSUME FOR IT THE OBLIGATIONS CONTAINED IN THIS WARRANTY AND PATRIOT ANTENNA NEITHER ASSUMES NOR AUTHORIZES ANY REPRESENTATIVE OR OTHER PERSON TO ASSUME FOR IT ANY OTHER LIABILITY IN CONNECTION WITH THE EQUIPMENT DELIVERED OR PROVIDED.

IN NO EVENT SHALL PATRIOT ANTENNA BE LIABLE FOR ANY LOSS OF PROFITS, LOSS OF USE, INTERRUPTION OF BUSINESS, OR INDIRECT, SPECIAL OR CONSEQUENTIAL DAMAGES OF ANY KIND.

In no event shall PATRIOT ANTENNA be liable for damages in an amount greater than the purchase price of the equipment.

Some states do not allow limitations on how long an implied warranty lasts, or allow the exclusion or limitation of incidental or consequential damages, so the above limitations or exclusions may not apply to you.

PATRIOT ANTENNA has the right to void the warranty when the antenna is installed by someone other than a certified installer.

Product Serial Number- \_\_\_\_\_

Date Purchased- \_\_\_\_\_

Patriot Antenna Systems

704 North Clark Street

Albion, MI 49224 USA

Tel: (517)629-5990

Fax: (517)629-6690

E-mail: [info@sepatriot.com](mailto:info@sepatriot.com)

## IMPORTANT!!!

INSTALLATION OF THIS PRODUCT SHOULD BE PERFORMED ONLY BY A PROFESSIONAL INSTALLER AND IS NOT RECOMMENDED FOR CONSUMER D.I.Y. (DO-IT-YOURSELF) INSTALLATIONS.

### WATCH FOR WIRES!

Installation of this product near power lines is dangerous. For your own safety, follow these important safety rules.

1. Perform as many functions as possible on the ground.
2. Watch out for overhead power lines. Check the distance to the power lines before starting installation. We recommend you stay a minimum of 6 meters (20 feet) from all power lines.
3. Do not use metal ladders.
4. Do not install antenna or mast assembly on a windy day.
5. If you start to drop antenna or mast assembly, get away from it and let it fall.
6. If any part of the antenna or mast assembly comes in contact with a power line, call your local power company. DO NOT TRY TO REMOVE IT YOURSELF! They will remove it safely.
7. Make sure that the mast assembly is properly grounded.

### WARNING

Assembling dish antennas on windy days can be dangerous. Because of the antenna surface, even slight winds create strong forces. For example, a 1.0m antenna facing a wind of 32 km/h (20 mph) can undergo forces of 269 N (60 lbs.). Be prepared to safely handle these forces at unexpected moments. Do not attempt to assemble, move or mount dish on windy days or serious, even fatal accidents may occur. PATRIOT ANTENNA SYSTEMS is not responsible or liable for damage or injury resulting from antenna installations.

### WARNING

Antennas improperly installed or installed to an inadequate structure are very susceptible to wind damage. This damage can be very serious or even life threatening. The owner and installer assumes full responsibility that the installation is structurally sound to support all loads (weight, wind & ice) and properly sealed against leaks. PATRIOT ANTENNA SYSTEMS will not accept liability for any damage caused by a satellite system due to the many unknown variable applications.

## Introduction

Thank you for purchasing your Patriot Commercial Antenna. We trust that you will find this to be a well designed product that will provide many years of reliable service. Please read this manual thoroughly before beginning assembly. For best results in the assembly process, perform each step in the same sequence as listed in this manual. Record the serial number of the unit on to page two for future reference and read the warranty information. The serial number plate can be found on the pedestal mount.

## Unpacking and Inspection

Shipping cartons should be unpacked and contents checked for damaged or missing parts. Should there be any parts that are damaged or missing, please contact technical support for replacement.

## Site Selection

The main objective of conducting a site survey utilizing a compass and inclinometer is to choose a mounting location on the ground that will give you the greatest amount of swing for azimuth and elevation for present as well as future use. A thorough pre-installation site survey is strongly recommended because it can alert you to any "look angle", soil, wind or other problems.

The first and most important consideration when choosing a prospective antenna site is whether or not the area can provide an acceptable "look angle" to the satellite. A site with a clear, unobstructed view facing south, southeast is required. Your antenna site must be selected in advance so that you will be able to receive the strongest signal available. Also consider obstructions that may occur in the future such as the growth of trees.

It is important to conduct an on-site survey with a portable antenna or with a compass and clinometer to avoid interference, obstructions, etc.

When selecting "look angle", be sure to observe and take readings approximately 10 deg to the left and right, above and below your selected "look angle".

Before Ground Pole Installation, the soil type should be checked because soil conditions vary widely in composition and load bearing capacity. A soil check will help you to determine the type and size of foundation required to provide a stable base for the antenna.

Before digging is done, information regarding the possibility of underground telephone lines, power lines, storm drains, etc., in the excavation area should be obtained from the appropriate agency.

As with any other type of construction, a local building permit may be required before installing an antenna. It is the property owner's responsibility to obtain any and all permits. Ground mounts are certified for 125 mph wind survival.

ITEM NO.	PART NO.	DESCRIPTION	REV	QTY	
1	2090-0001G	REFLECTOR, 090 ASSEM		000	1
	2100-0001G	REFLECTOR, 1.0 ASSEM		000	1
	2120-0001G	REFLECTOR, 1.2 ASSEM		000	1
2	209083G	TUBE, .90m TX FEED SUPPORT		000	1
	210004G	TUBE, 1.0m SUPT PLAT BENT	000		1
	212004G	TUBE, 1.2m TX FEED SUP BENT		000	1
3	209082G	ADAPTOR, TX ELEVATION	000		2
4	210080G	BRKT., 3"PIPE GRAY	000		2
5	210081G	BRKT, AZIMUTH		000	1
	3HP0003	PREBAG, .9,1.0,1.2m SMALL PARTS	000		1
6	TXFD-KUL	FEED HORN, KU ASSEM W/HOLDER	002		1
7	TXOMT-KUL	OMT, TRANSMIT/OMTFILTER FOR KU	000		1

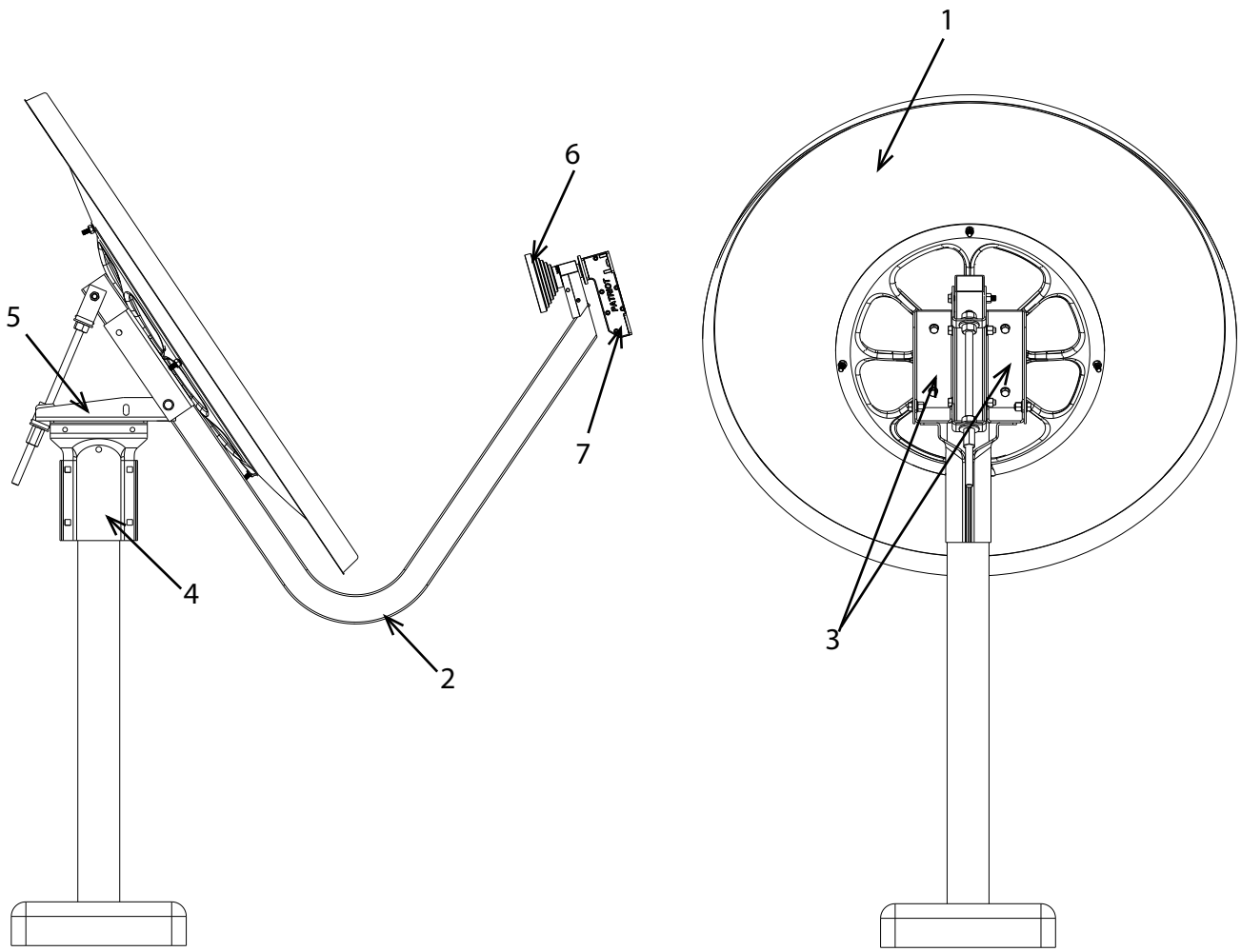

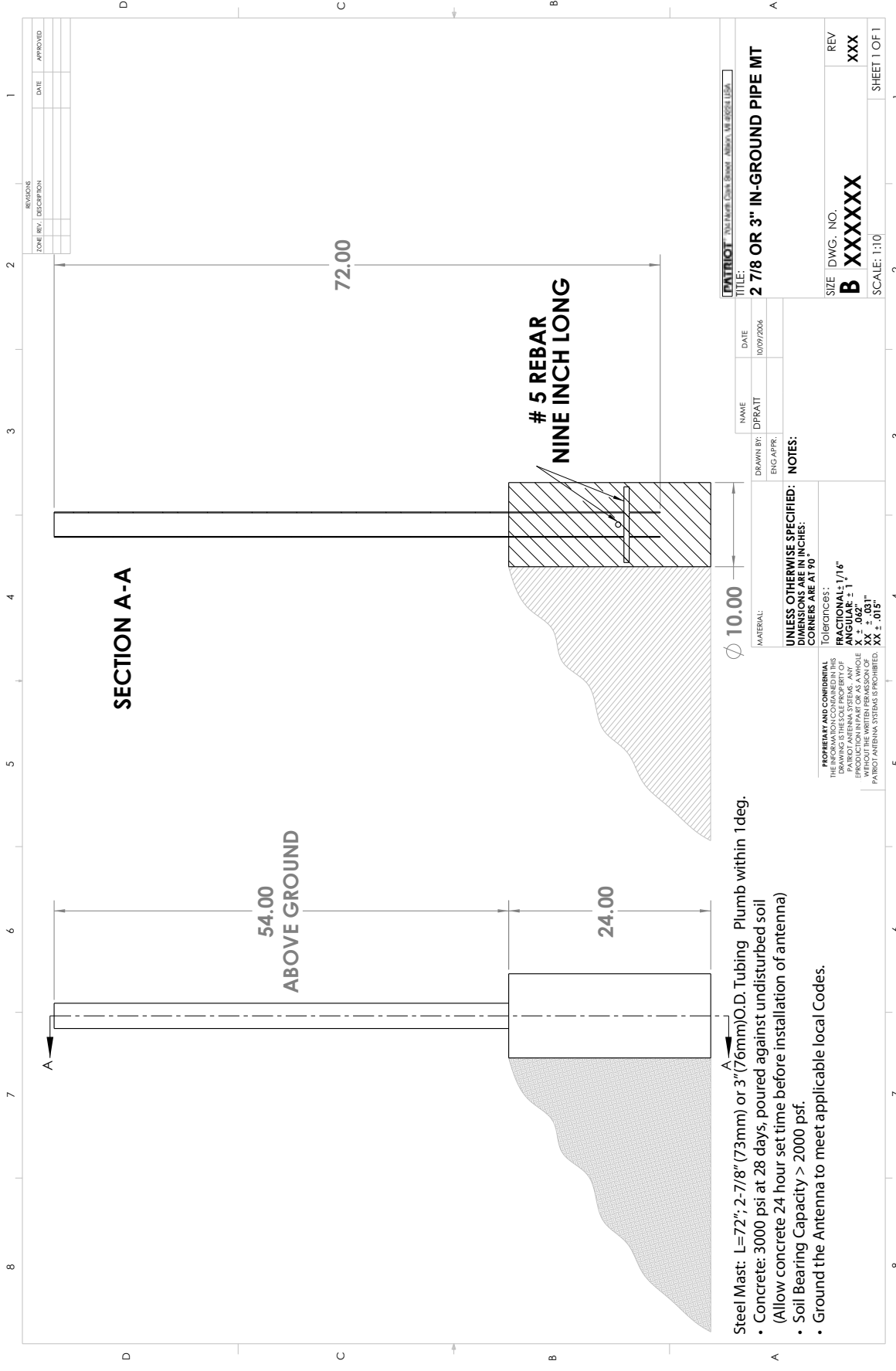

REVISIONS	DATE	APPROVED
ZONE REV / DESCRIPTION		

PATRIOT™ TOLL FREE: 1-800-456-3333	
NAME	DATE
DRAWN BY: DPRATT	10/07/2006
ENG APPR:	
TITLE: 2 7/8 OR 3" IN-GROUND PIPE MT	
SIZE	DWG. NO.
B	XXXXXX
SCALE: 1:10	REV
	XXX
	SHEET 1 OF 1

**UNLESS OTHERWISE SPECIFIED:**  
 DIMENSIONS ARE IN INCHES:  
 CORNERS ARE AT 90°

**TOLERANCES:**  
 FRACTIONAL: 1/16"  
 ANGULAR: 1°  
 DECIMAL: ± .005"  
 HOLE: ± .003"  
 POSITION: ± .015"

**PROPRIETARY AND CONFIDENTIAL**  
 THIS DRAWING IS THE SOLE PROPERTY OF  
 PATRIOT ANTENNA SYSTEMS. ANY  
 REPRODUCTION OR TRANSMISSION OF  
 THIS DRAWING WITHOUT THE WRITTEN PERMISSION OF  
 PATRIOT ANTENNA SYSTEMS IS PROHIBITED.

- Steel Mast: L=72"; 2-7/8" (73mm) or 3" (76mm) O.D. Tubing Plumb within 1 deg.
- Concrete: 3000 psi at 28 days, poured against undisturbed soil (Allow concrete 24 hour set time before installation of antenna)
  - Soil Bearing Capacity > 2000 psf.
  - Ground the Antenna to meet applicable local Codes.

## Non-Penetrating Mount (optional)

1. Assemble the Non-Penetrating mount per the supplied instructions to provide the mast for the mount installation.
2. Refer to the ballast chart for the required ballast to be placed in the Non-Pen Ballast Trays.

NOTE: Higher elevation angles can use less ballast. If there are any possible future elevation adjustments that could result in a lower elevation angle **use the 22 deg elevation angle from the chart for the ballast requirement!**

<b>90cm Ballast Chart</b> (use single tray PTX-NP300S)			
Elevation (deg)	Ballast Required (lbs)		
	Wind Speed (mph)		
	80	100	125
22	207	391	679
40	162	305	529
60	93	176	305

<b>100cm Ballast Chart</b> (use single tray PTX-NP 300S)			
Elevation (deg)	Ballast Required (lbs)		
	Wind Speed (mph)		
	80	100	125
22	259	480	826
40	202	374	644
60	116	216	372

<b>120cm Ballast Chart</b> (must use dual tray PTX-NP300D)			
Elevation (deg)	Ballast Required (lbs)		
	Wind Speed (mph)		
	80	100	125
22	411	733	1236
40	321	572	964
60	185	330	556

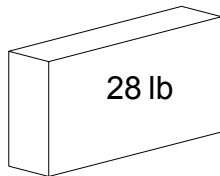

4x8x16 Block

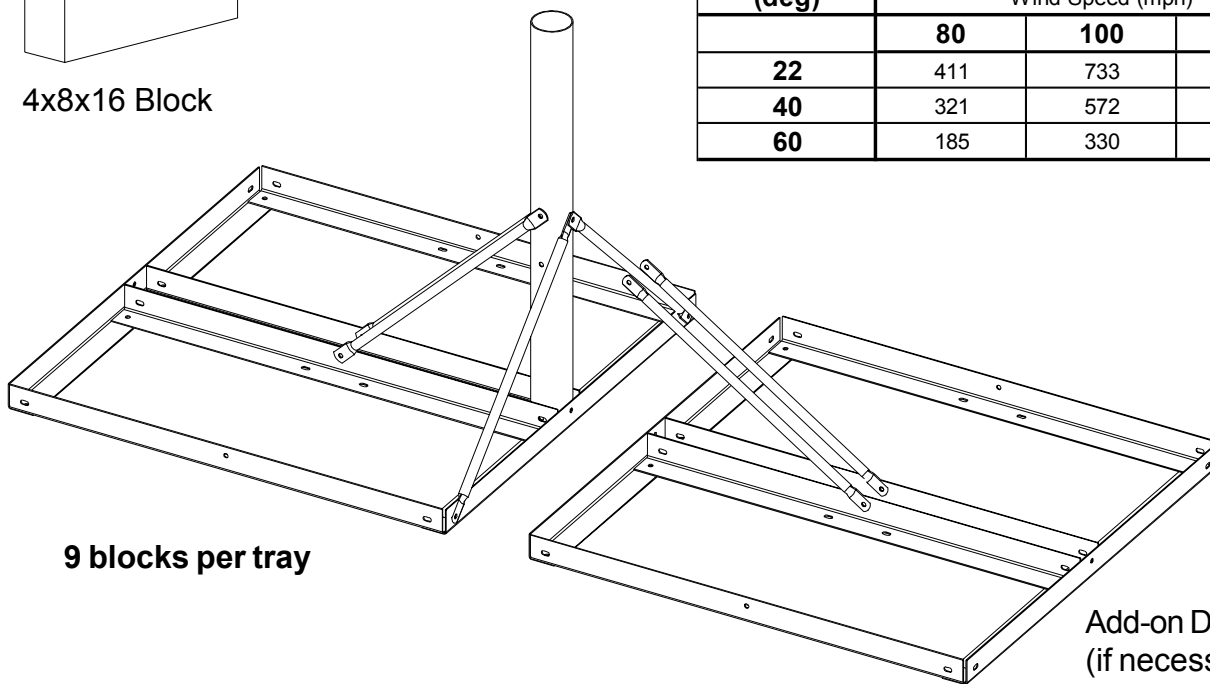

9 blocks per tray

Add-on Dual Tray (if necessary)

# Az-EI Mount Assembly

1. Using the hardware illustrated, assemble the Pipe brackets, Azimuth bracket, and Clevis bracket as shown. (Place Az/EI mount after assembly on to ground pole or NPRmmount.)

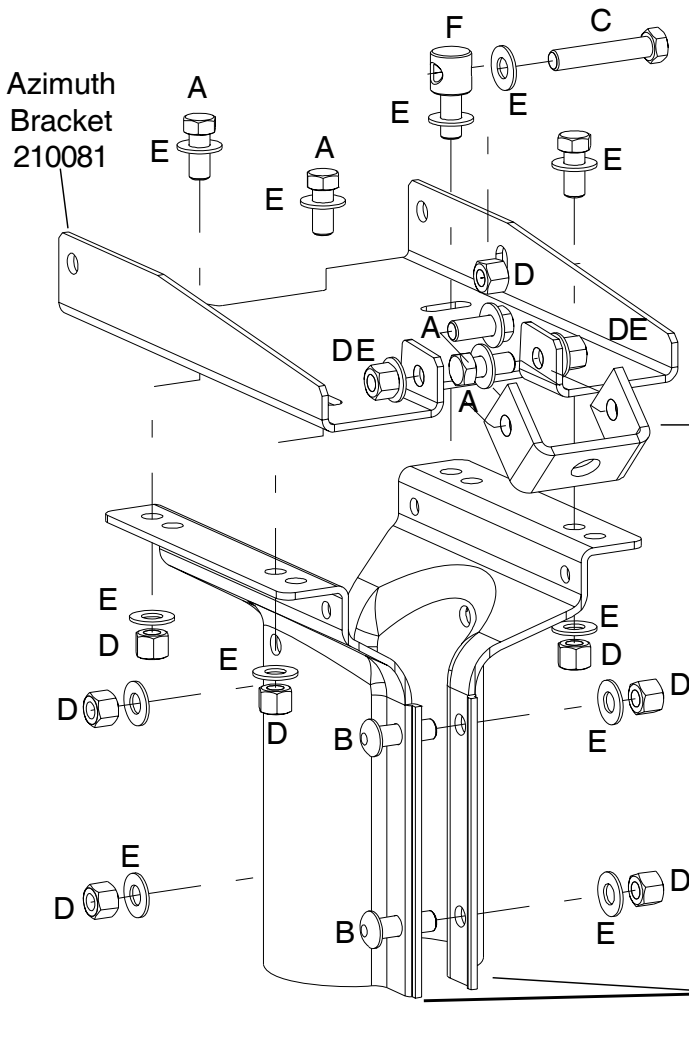
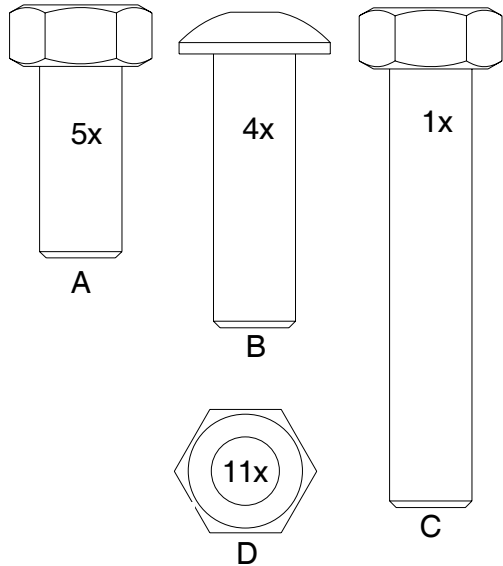

Lower Clevis, Elevation 210082

NOTE:  
IF LOWER ELEVATION IS DESIRED THEN MAKE SURE CLEVIS IS ORENTATED AS PICTURED

## Mount Assembly Continued

**NOTE: Ka band Antenna's ,Take extra care in assembly and handling - Do Not Stack!.**

2. Attach the Elevation Brackets (2) to the Feed Support Tube and the Azimuth Bracket as shown. Partially tighten all this hardware at this time.

3. Assemble the Elevation rod with nuts and washers as shown.

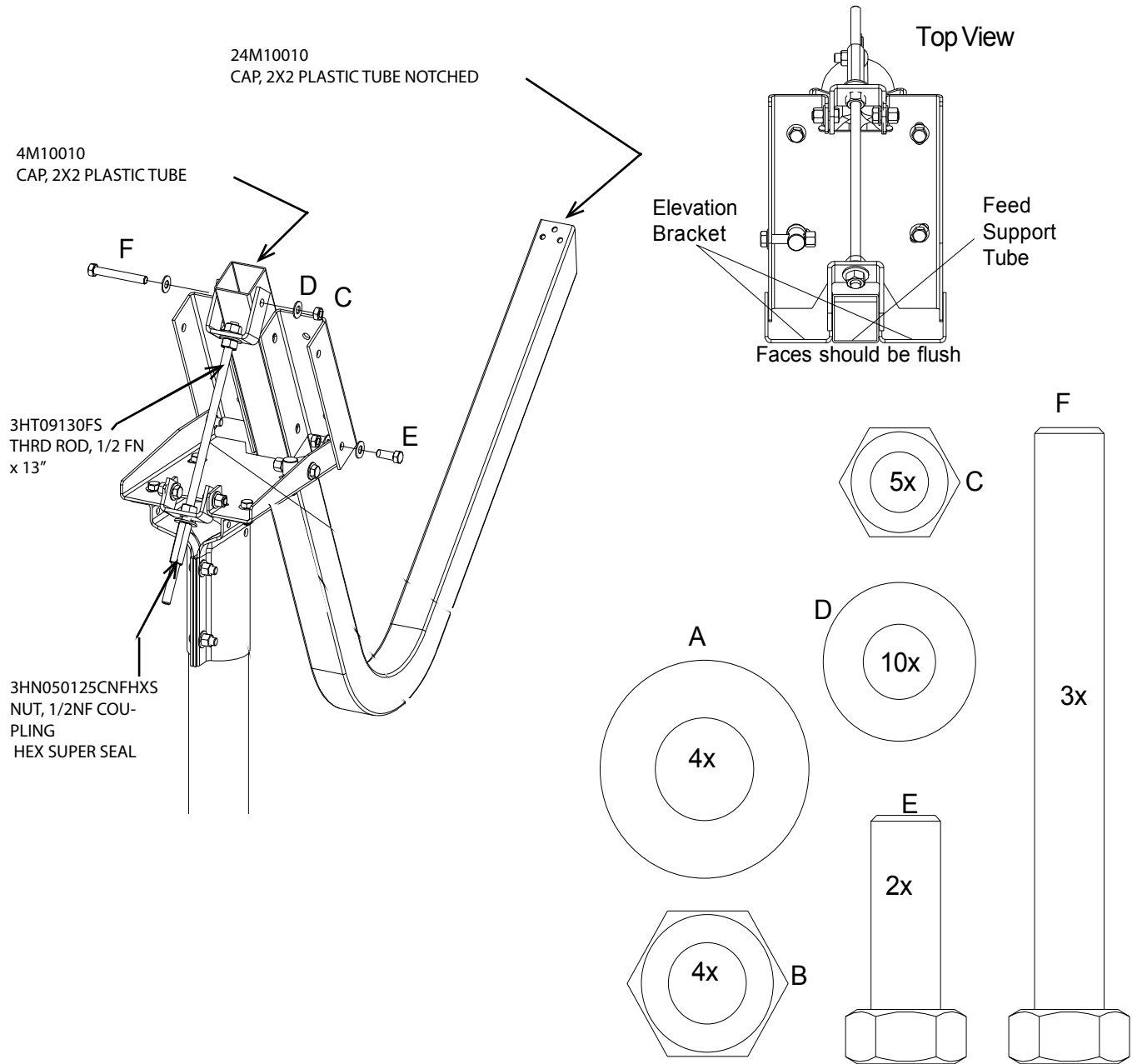

## Reflector Assembly

1. Attach the Antenna Assembly to the Elevation Brackets
2. Tighten the Elevation Bracket hardware.

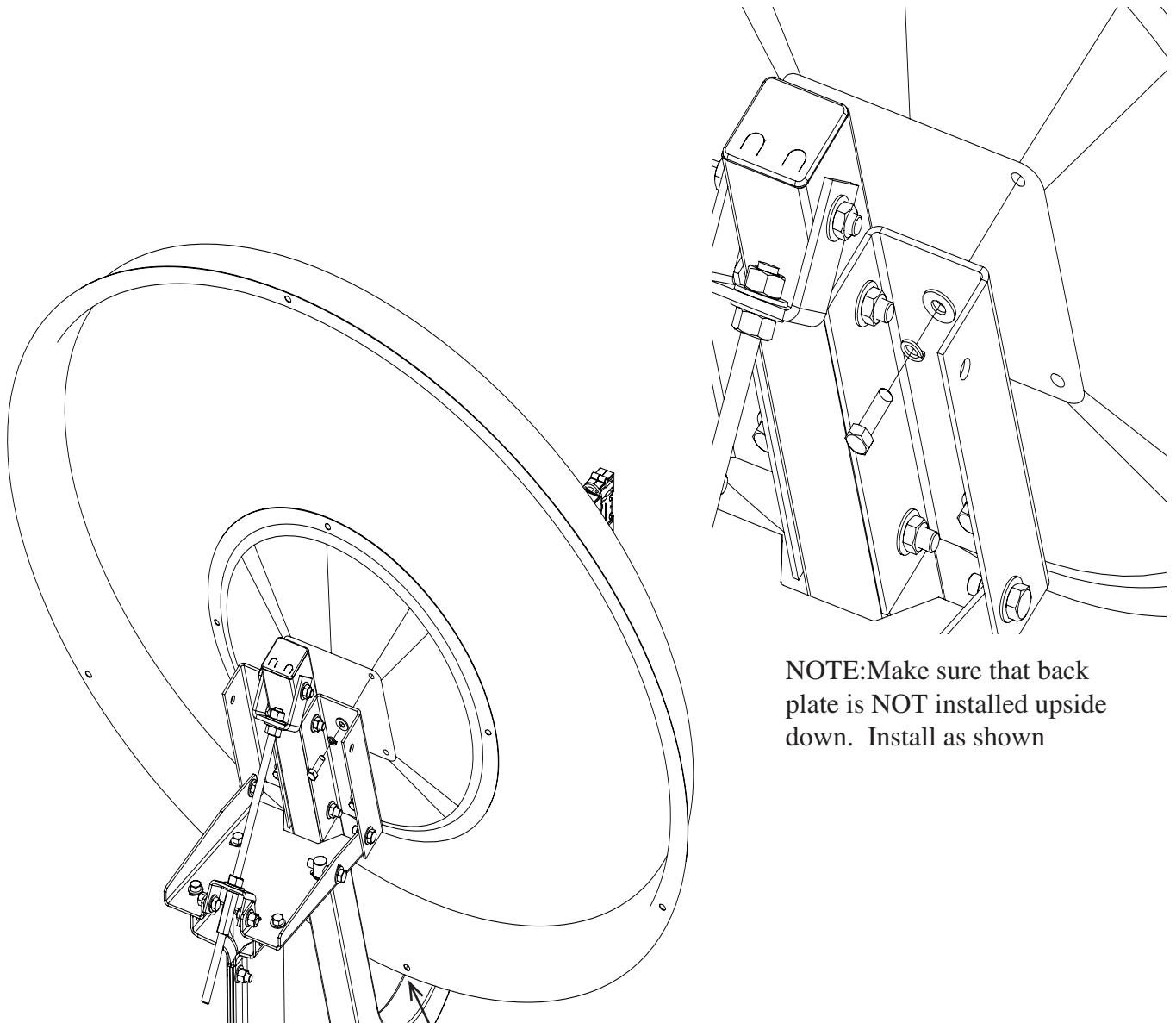

NOTE: Make sure that back plate is NOT installed upside down. Install as shown

INSTALL .90 REFLECTOR ASSEMBLY WITH PUNCHED HOLE TOWARDS FEED BOOM AS PICTURED

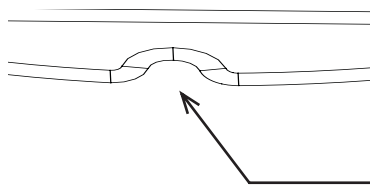

INSTALL BACK PLATTER WITH THIS NOTCH DOWN (NOTCH IS ONLY ON 1.0 AND 1.2m DISH ASSEMBLIES)

## Antenna Pointing

NOTE: The Reflector contains a 22 degree offset look angle for the 1.0/1.2 and 21 degree angle for the .90m. Therefore, when the reflector aperture is perpendicular to the ground, the antenna is actually looking 22 degrees, or 21 degrees for the .90, in elevation. All mount hardware should be firm, but not tight.

1. Adjust the reflector up or down in elevation by turning the two 1/2" hex nuts at the Clevis until the desired elevation is measured (taking reading from the face of the reflector).

Elevation of Satellite above horizon = Measured angle from face of reflector minus 22 or 21 respectfully.

2. Azimuth Adjustment: With the electronics set to acquire the satellite, rotate the antenna in azimuth until the satellite is found. Roughly obtain the strongest signal and tighten the hardware on the Pipe Brackets.

NOTE: If signal is not found on first pass of Azimuth, adjust elevation up or down in 2 deg increments until signal is found.

3. Peak the satellite signal by fine adjustments made in both azimuth and elevation until the optimum signal is achieved.

Note: With Azimuth hardware snug (loose enough to allow adjustment), turning the Azimuth bolt allows  $\pm 3$  deg fine adjustment.

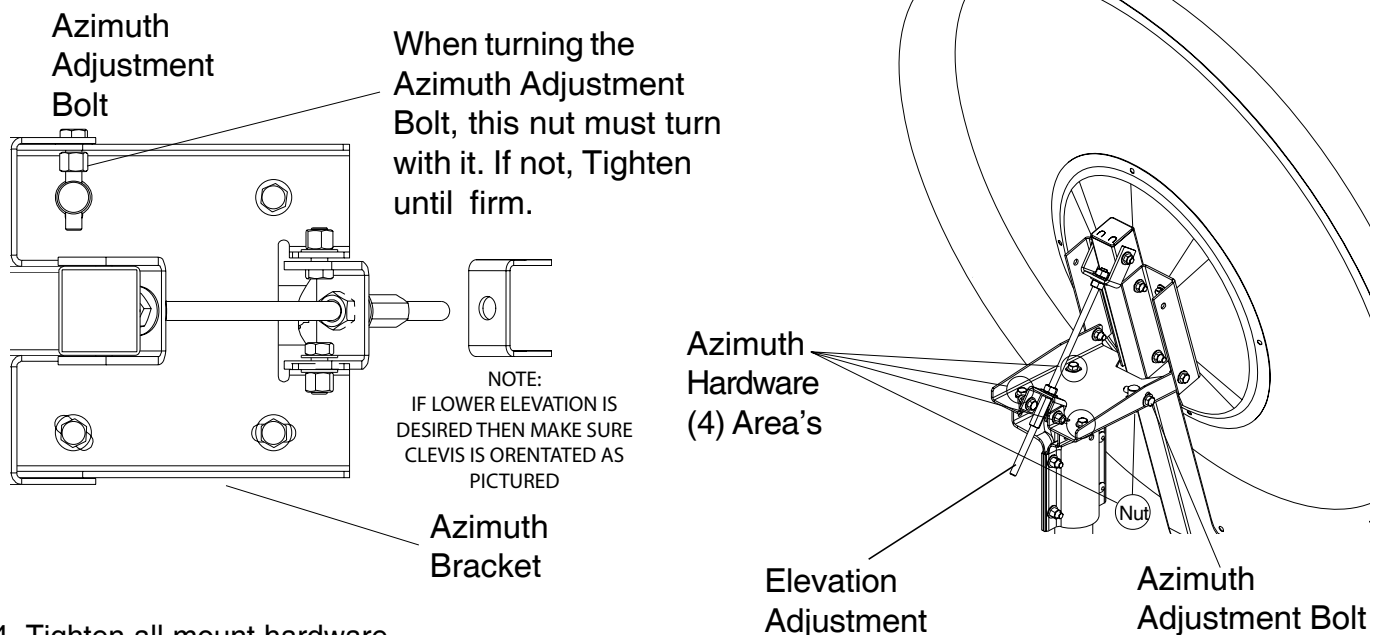

4. Tighten all mount hardware

5. Patriot recommends the use of cross pol nulling using a spectrum analyzer during TX/RX installations. After tightening the azimuth and elevation hardware, peak the co-pol signal using the spectrum analyzer. Then rotate the feed assemble roughly 90 degrees to obtain a cross pol null. Fine tune the null. The scale on the feed horn can be used with the tick mark on feed holder top or the seam between feed holder top and bottom. The tick mark and seam are 90 deg. apart. Note that changes may be necessary to the resolution and video bandwidth to bring the signal above the noise floor. Note the angle of optimum cross pol null. Rotate the feed back exactly 90 degrees and tighten the feed clamp.

## Grounding

### Grounding Antenna Feed Cables

1. Ground antenna feed cables in accordance with current National Electric code and local electric codes. The illustration shows a typical grounding method.

Clamps that provide a solid connection between ground wire and a ground source should be used.

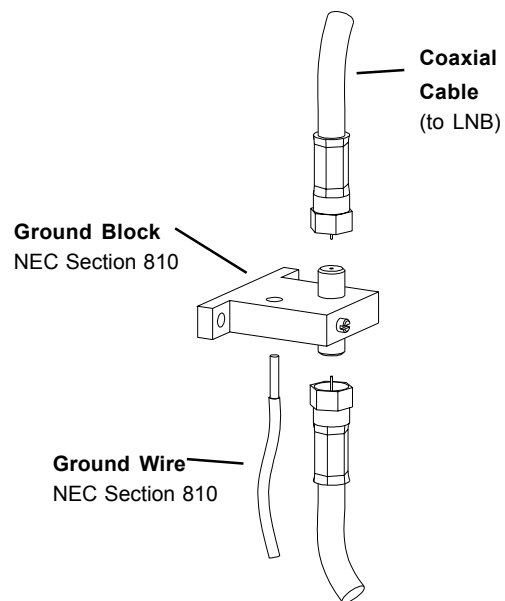

### Grounding Non-Penetrating Mount Frame (if applicable)

1. Ground the Non-Penetrating mount frame. The illustration shows a typical grounding method.

Refer to the NEC Section 810 and local electric codes for specific instructions on grounding the remaining end of the ground wire.

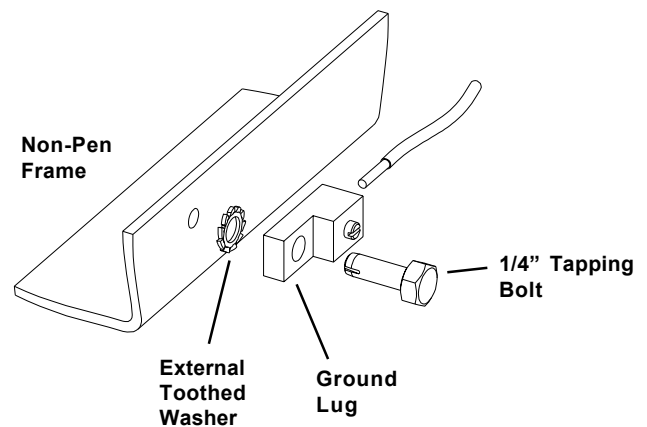

### Antenna Pointing

- 1) Begin by obtaining the correct Az/EI pointing data for the satellite of interest based for your site location.
- 2) Using an inclinometer or position readout form controller placed on the enclosure drum surface, position the antenna to the specified elevation angle.
- 3) Manually scan the antenna (back-and-forth in the azimuth around the direction of the specified azimuth angle) to achieve the maximum transponder signal.
- 4) Next repeat the procedure for elevation.
- 5) Repeat this procedure alternating between the azimuth and elevation until maximum transponder signal is achieved.

Notes:

### Feed Adjustment (Polarity tuning)

1. Adjust the Feed to the appropriate skew angle using the provided scale reference.

NOTE: Refer to the chart on back for polarization angle. Elevation and polarity are both dependent on site azimuth and the difference between satellite and site longitude.

NOTE: Some satellites have a slant angle with respect to the satellite belt angle. Contact the satellite operator for details.

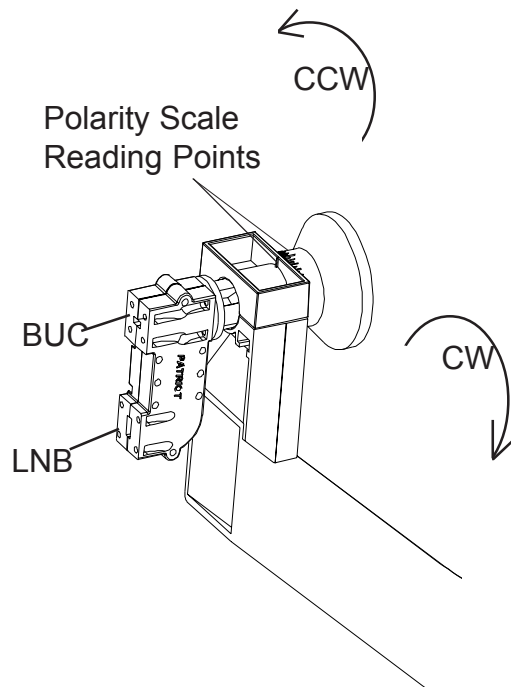

### Feed Rotation Chart

Install site west of satellite	Install site East of satellite	
CW	CCW	Northern Hemisphere
CCW	CW	Southern Hemisphere

### Feed Assembly

1. Attach the relevant Feed Assembly.
2. Insert the Feed Assembly into the Feed holder and assemble to the Feed Support Tube using the hardware illustrated below.
3. Insert the Feed Support Tube into the support tube.

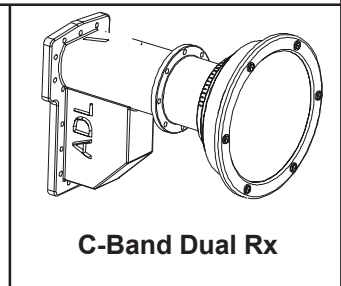
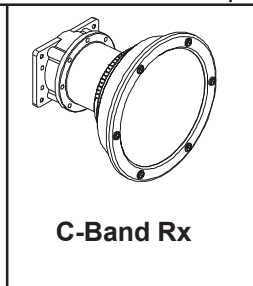
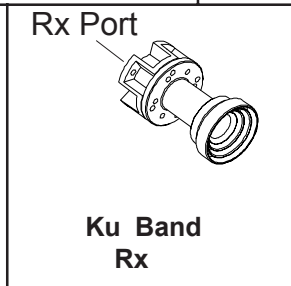
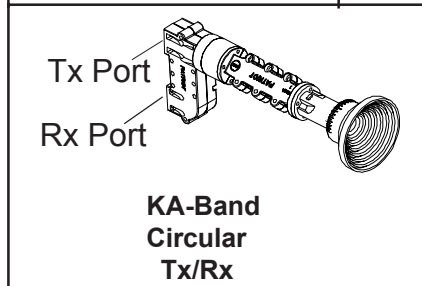
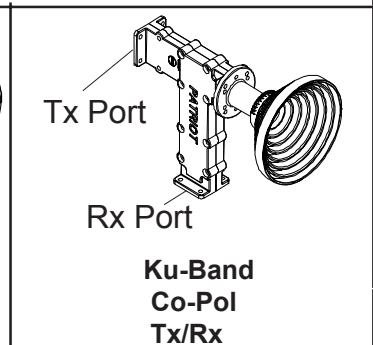
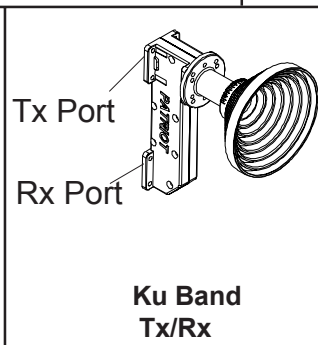
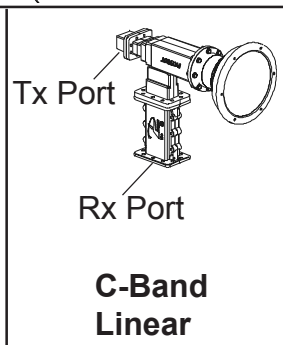
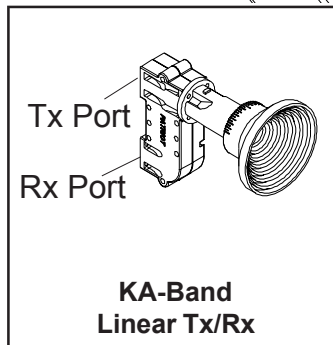
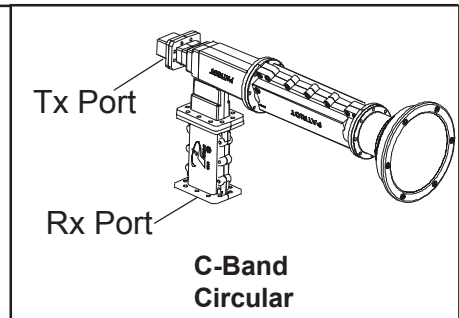
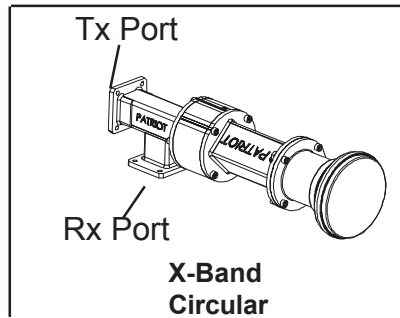
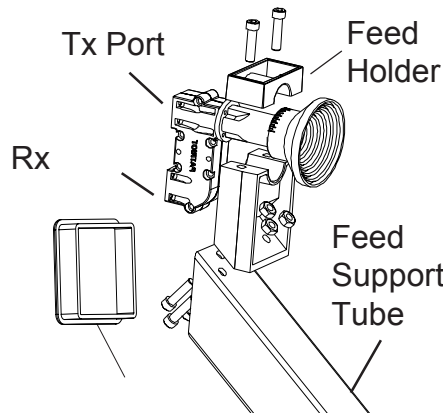

# Polarization Chart

Delta Longitude =  $|LONG_{sat} - LONG_{site}|$

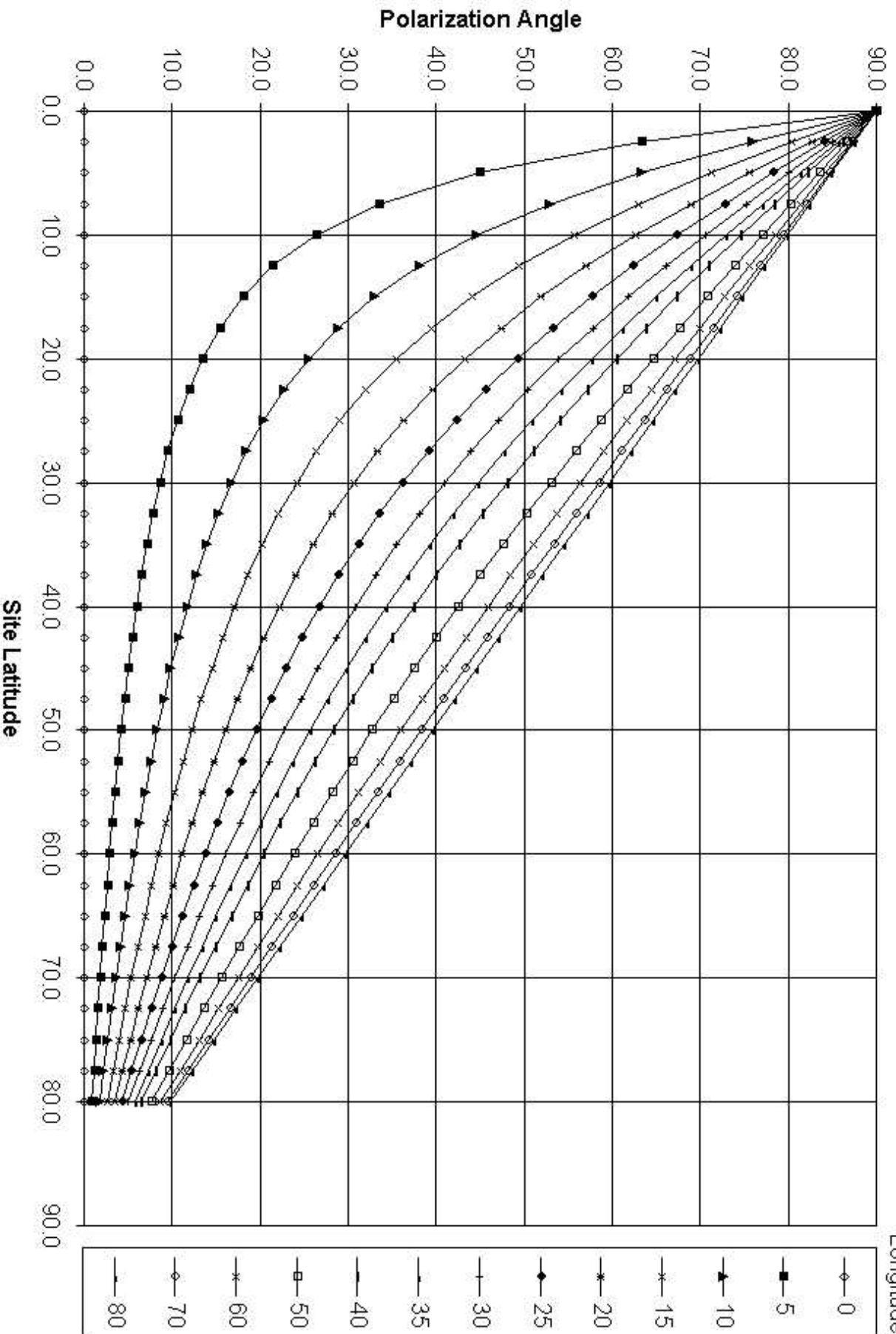

**Specifications**

**Electrical**

	<i>Ku Band</i> <b>.90M</b>	<i>Ka Band</i> <b>.90M</b>	<i>Ku Band</i> <b>1.0m - 1.2m</b>	<i>Ka Band</i> <b>1.0m - 1.2m</b>
Tx Band(GHz)	13.75 - 14.50	29.50 - 30.00	13.75 - 14.50	29.50 - 30.00
Rx Band(GHz)	10.70 - 12.75	19.70 - 20.20	<u>10.70 - 12.75</u>	<u>19.70 - 20.20</u>
Tx Gain dBi (Midband)	40.9	47.1	41.90   43.50	48.10   49.70
Rx Gain dBi (Midband)	39.3	43.6	40.30   41.80	44.60   46.00
Efficiency	70%	65%	70%	65%
Side Lobes	ITU-580-5		ITU-580-5	ITU-580-5
Cross Polarization (on axis)	35dB		35dB	35dB

**Mechanical**

Antenna Size	90cm (35.4")	1.0m (39.4") 1.2m (47.3")
Offset Angle	21 degrees	22 degrees
F/D	0.65	0.635
Operational Wind	50mph	50mph
Survival Wind	125mph	125mph
Operational Temp	-40 to 140 F	-40 to 140 F
Survival Temp	-60 to 180 F	-60 to 180 F
Rain	Operational = 1/2in./hr Survival = 3in./hr	Operational = 1/2in./hr Survival = 3in./hr
Ice	1 in. Radial -or- 1/2 in. + 60mph wind	1 in. Radial -or- 1/2 in. + 60mph wind
Pole Size	2-7/8" or 3" OD	2-7/8" or 3" OD

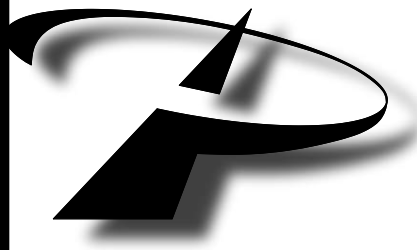
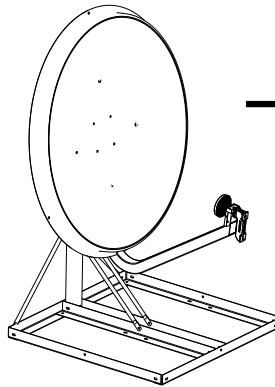

***PATRIOT ANTENNA SYSTEMS***  
***704 NORTH CLARK STREET***  
***ALBION, MICHIGAN 49224 USA***  
***WWW.SEPATRIOT.COM***